



features

- Excellent anti-sulfuration characteristic due to using high sulfuration-proof inner top electrode material
- Current detecting resistors for power supply, motor circuits, etc
- High reliability and performance with resistance tolerance $\pm 1.0\%$, T.C.R. $\pm 100 \times 10^{-6}/K$
- Suitable for both reflow and flow solderings
- Products with lead free termination meet EU RoHS requirements. EU RoHS regulation is not intended for Pb-glass contained in electrode, resistor element and glass.
- AEC-Q200 Qualified



dimensions and construction

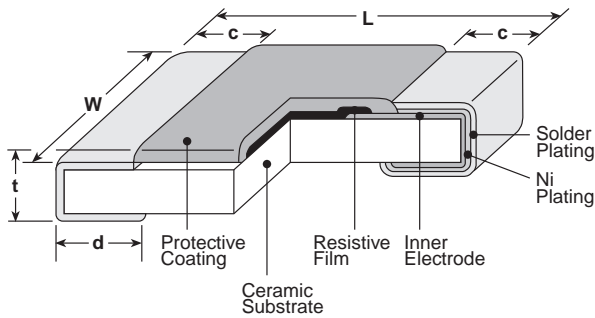

NEW	Type (Inch Size Code)	Resistance Range	Dimensions inches (mm)				
			L	W	c	d	t
	1E (0402)	1 - 10	.039 ^{+0.006} _{-.004} (1.0 ^{+0.1} _{-0.05})	.020 ^{+0.006} _{-.004} (0.5 ^{+0.1} _{-0.05})	.008 \pm .004 (0.2 \pm 0.1)	.010 \pm .004 (0.25 \pm 0.1)	.014 \pm .002 (0.35 \pm 0.05)
	1J (0603)	0.1 - 0.43	.063 \pm .008 (1.6 \pm 0.2)	.031 ^{+0.006} _{-.004} (0.8 ^{+0.15} _{-0.1})	.016 \pm .004 (0.4 \pm 0.1)	.018 \pm .004 (0.45 \pm 0.1)	.018 \pm .004 (0.45 \pm 0.1)
		0.47 - 10					
	2A (0805)	0.1 - 0.43	.079 \pm .008 (2.0 \pm 0.2)	.049 \pm .004 (1.25 \pm 0.1)	.016 \pm .008 (0.4 \pm 0.2)	.016 ^{+0.008} _{-.004} (0.4 ^{+0.2} _{-0.1})	.02 \pm .004 (0.5 \pm 0.1)
		0.47 - 10				.012 ^{+0.008} _{-.004} (0.3 ^{+0.2} _{-0.1})	
	2B (1206)	0.1 - 0.43	.126 \pm .008 (3.2 \pm 0.2)	.063 \pm .008 (1.6 \pm 0.2)	.02 \pm .012 (0.5 \pm 0.3)	.02 ^{+0.008} _{-.004} (0.5 ^{+0.2} _{-0.1})	.024 \pm .004 (0.6 \pm 0.1)
		0.47 - 10				.016 ^{+0.008} _{-.004} (0.4 ^{+0.2} _{-0.1})	
	2E (1210)	0.1 - 0.39	.126 \pm .008 (3.2 \pm 0.2)	.102 \pm .008 (2.6 \pm 0.2)	.02 \pm .012 (0.5 \pm 0.3)	.02 ^{+0.008} _{-.004} (0.5 ^{+0.2} _{-0.1})	.024 \pm .004 (0.6 \pm 0.1)
		0.43 - 10				.016 ^{+0.008} _{-.004} (0.4 ^{+0.2} _{-0.1})	

Derating Curve

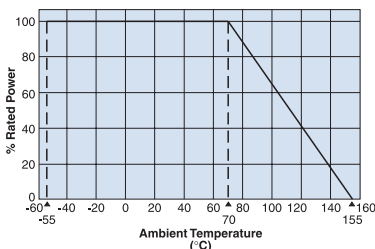

For resistors operated at an ambient temperature of 70°C or above, a power rating shall be derated in accordance with the derating curve.

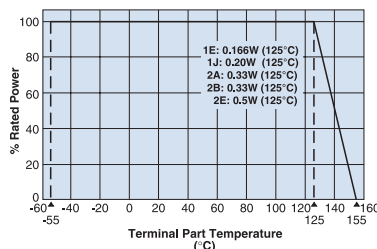

For resistors operated at a terminal part temperature of described for each size or above, a power rating shall be derated in accordance with the derating curve.

Please refer to "Introduction of the derating curve based on the terminal part temperature" in the beginning of our catalog before use.

SR73 2A (0.5W), SR73 2B (0.5W), SR73 2E (0.66W)

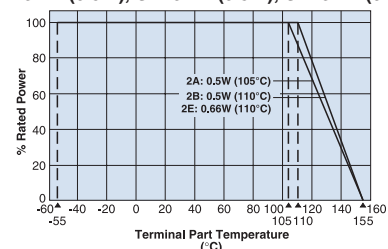

ordering information

SR73	2B	RT	TD	R10	J
Type	Size	Termination Material	Packaging	Nominal Resistance	Tolerance
	NEW 1E: 0.166W 1J: 0.2W 2A: 0.33W, 0.5W 2B: 0.33W, 0.5W 2E: 0.5W, 0.66W	RT: Sn	TD: 7" 4mm pitch punch paper TP: 0402 only, 7" 2mm pitch paper TPL: 0402 only, 2mm pitch paper For further information on packaging, please refer to Appendix A	$\pm 2\%$, $\pm 5\%$: 2 significant figures + 1 multiplier "R" indicates decimal on values $< 10\Omega$ $\pm 1\%$: 3 significant figures + 1 multiplier "R" indicates decimal on values $< 100\Omega$	F: $\pm 1\%$ G: $\pm 2\%$ J: $\pm 5\%$

Specifications given herein may be changed at any time without prior notice. Please confirm technical specifications before you order and/or use.

6/28/18

applications and ratings

NEW	Part Designation	Power Rating	Rated Ambient Temperature	Rated Terminal Part Temp.	T.C.R. (ppm/°C) Max.	Resistance Range			Operating Temperature Range
						F (±1%) E-24, E-96	G (±2%) E-24	J (±5%) E-24	
	SR731ERT (0402)	0.166W	70°C	125°C	±200	1Ω - 10Ω	1Ω - 10Ω	1Ω - 10Ω	-55°C to +155°C
	SR731JRT (0603)	0.2W	70°C	125°C	±200	0.2Ω - 10Ω	0.2Ω - 10Ω	0.2Ω - 10Ω	
	SR732ART (0805)	0.33W	70°C	125°C	±300	—	—	0.1Ω - 0.18Ω	
					±100	0.47Ω - 10Ω	—	—	
					±200	0.2Ω - 0.43Ω	0.2Ω - 10Ω	0.2Ω - 10Ω	
	SR732ART (0805)	0.5W*	—	105°C	±250	0.1Ω - 0.18Ω	0.1Ω - 0.18Ω	0.1Ω - 0.18Ω	
					±100	0.47Ω - 10Ω	—	—	
					±200	0.2Ω - 0.43Ω	0.2Ω - 10Ω	0.2Ω - 10Ω	
	SR732BRT (1206)	0.33W	70°C	125°C	±250	0.1Ω - 0.18Ω	0.1Ω - 0.18Ω	0.1Ω - 0.18Ω	
					±100	0.47Ω - 10Ω	—	—	
					±200	0.2Ω - 0.43Ω	0.2Ω - 10Ω	0.2Ω - 10Ω	
	SR732BRT (1206)	0.5W*	—	110°C	±250	0.1Ω - 0.18Ω	0.1Ω - 0.18Ω	0.1Ω - 0.18Ω	
					±100	0.47Ω - 10Ω	—	—	
					±200	0.2Ω - 0.43Ω	0.2Ω - 10Ω	0.2Ω - 10Ω	
	SR732ERT (1210)	0.5W	70°C	125°C	±250	—	—	0.1Ω - 0.18Ω	
					±100	0.43Ω - 10Ω	—	—	
					±200	0.2Ω - 0.39Ω	0.2Ω - 10Ω	0.2Ω - 10Ω	
	SR732ERT (1210)	0.66W*	—	110°C	±200	0.2Ω - 0.39Ω	0.2Ω - 10Ω	0.2Ω - 10Ω	
					±100	0.43Ω - 10Ω	—	—	
					±250	—	—	0.1Ω - 0.18Ω	

Rated voltage = $\sqrt{\text{Power rating} \times \text{resistance value}}$ or max. working voltage, whichever is lower

* Please use the derating curve based on the terminal part temperature in graph below.

If any questions should arise whether to use the "Rated Ambient Temperature" or the "Rated Terminal Part Temperature," please give priority to the "Rated Terminal Part Temperature." Prior to use and for more details refer to "Introduction of the derating curves on the terminal part temperature" in the beginning of the catalog.

environmental applications

Performance Characteristics

Parameter	Requirement $\Delta R \pm(\%+0.005\Omega)$		Test Method
	Limit	Typical	
Resistance	Within specified tolerance	—	25°C
T.C.R.	Within specified T.C.R.	—	+25°C/-55°C and +25°C/+125°C
Overload (Short time)	±2%	±0.5%	Rated voltage x 2.5 for 5 seconds
Resistance to Solder Heat	±1%	±0.3%	260°C ± 5°C, 10 seconds ± 1 second
Rapid Change of Temperature	±1%	±0.3%	-55°C (30 minutes), +125°C (30 minutes), 100 cycles
Moisture Resistance	±2%	±1%	40°C ± 2°C, 90%-95% RH, 1000 hours, 1.5 hr ON, 0.5 hr OFF cycle
Endurance at 70°C	±2%	±1%	70°C ± 2°C, 1000 hours, 1.5 hr ON, 0.5 hr OFF cycle
High Temperature Exposure	±1%	±0.3%	+155°C, 1000 hours
Sulfuration Test	±5%	—	Soaked in industrial oil with sulfur substance 3.5% contained, 105°C ± 3°C, 500 hours